

PRODUCT DATA SHEET

RKA-SS3G15E-F17 - 1750 RPM

DESCRIPTION



SPECIFICATIONS

MAX GPM 3
 MAX PSI..... 1500
 POWER EBHP 3
 STROKE MM 9.8
 MAX TEMP 140°
 INLET THREAD 1/2" F

MAX LMP..... 11.4
 MAX BAR 105
 BORE DIA. MM..... 18
 WEIGHT LBS..... 22
 OIL CAPACITY..... 15oz
 DISCHARGE THREAD 3/8" F

DIMENSIONS

RKA-SS E version + F17
 Hollow shaft pump \varnothing 1" 1/8

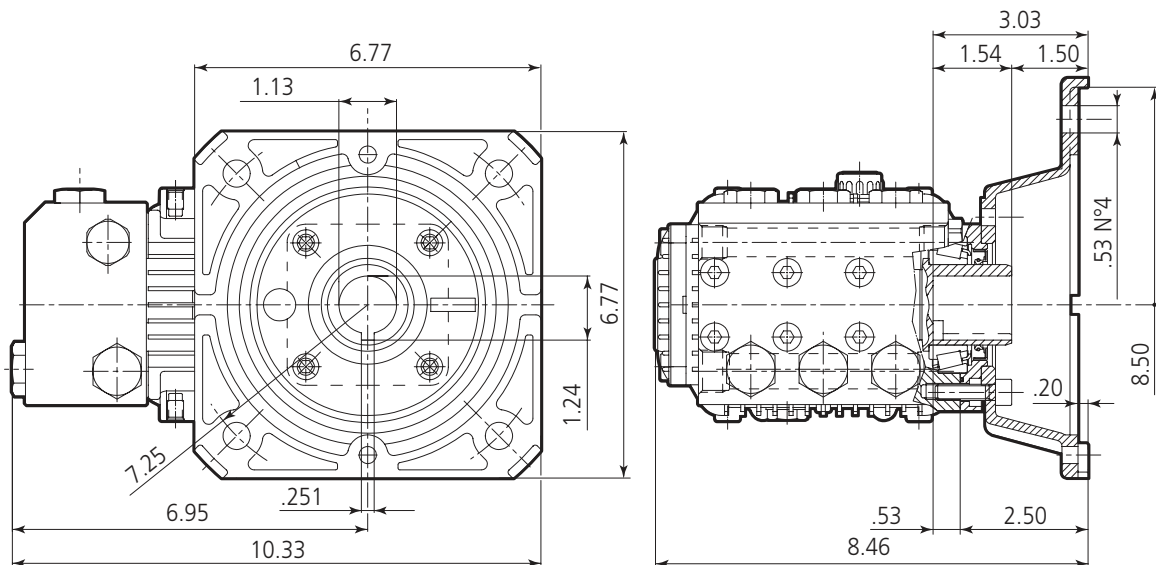

SPECIAL FEATURES

WET END

- **Manifold:**
 - **316L - Stainless Steel Block Style:** Strength and no porosity = long life.
 - **Inlet and Discharge Ports:** 1/2" inlet and 3/8" discharge.
 - **Offset Discharge Ports:** High efficiency, smooth flow
 - **Bolts:** 8 Bolts, 6mm, stainless steel.
- **Valves:**
 - **Ultra Form Cages:** Durable, strength, and long life.
 - **Poppets, Seat and Spring:** 316 series stainless steel.
 - **Valve Caps:** Machined 316L series stainless steel.
- **Packing and Plungers:**
 - **High Pressure Packing:** "V" style (D-1) Viton (cotton duct weave base) strong and tightens under load.
 - **Low Pressure Seals:** "U" cup double lip Viton, good positive seal.
 - **Support and Guides:** Machined stainless steel, 2-piece construction and special back-up ring to assure proper plunger alignment, maximize packing and seal life.
 - **Plungers:** Special aluminum oxide blend, solid ceramic long life, strong and durable ultra thick design.

DRIVE END

- **Bearings:** Premium oversized taper for maximum life and load dispersement.
- **Bearings Supports:** Precision die-cast and machined to assure concentricity and alignment.
- **Crankcase:** Precision die-cast, large cooling fins and covered with a special anti-corrosion finish.
- **Rear Cover:** Precision die-cast, O-Ring sealed and bayonet style sight glass for positive sealing and locking (no threads to loosen). This is an "AR" original. Oil drain plug.
- **Plunger Rods:** Stainless steel construction for strength, back-up and O-ring plunger sealing

system. Special acorn style retaining nuts and SST slingers.

- **Rod Pins:** Precision ground and hardened steel, oversized for load dispersement.
- **Connection Rods:** 1-piece special alloy bronze for higher pressures, oversized for maximum strength, load dispersement, and life. Heavy pin area construction.
- **Crankshaft:** Forged, precision ground and hardened for extremely long life and durability. Available in 24mm solid shaft, 5/8" and 1-1/8" hollow shafts, hydraulic motor and gearbox drives. Shaft key set screws are standard on high-speed version for long shaft life.
- **Oil Seals and O-Rings:** Triple lip oil seals, long life and much less leak prone. All are constructed of Buna-N rubber. The O-Rings have stainless steel garder springs for assure constant tension on the sealing surface.
- **Oil Drains:** Quantity of 2. One in the rear cover and one in the bottom of the crankcase.
- **Oil Capacity:** 15 oz.
- **Oil Sight Glasses:** Rear cover and non-drive side bearing housing.

EXTRA FEATURES

- **Dyno Proven:** All pumps are dyno tested to assure the theroretical design meets the actual design.
- **Valve Design:** Each pump series has a valve design that optimizes its highest efficiency.
- **Hot Water:** High temperature kits are available to 180°F.
- **Wet End Repair:** Very simple no special tools are required.
- **Mounting Flanges:** Multiple flanges are available.
- **Buna-N:** Elastomers available.