

### DESCRIPTION



### SPECIFICATIONS

MAX GPM .....	5.5	MAX LMP .....	20.8
MAX PSI .....	2600	MAX BAR .....	180
POWER EBHP .....	11.3	BORE DIA. MM .....	18
STROKE MM .....	16.6	WEIGHT LBS .....	18
MAX TEMP .....	140°	OIL CAPACITY .....	13.35oz
INLET THREAD .....	1/2" F	DISCHARGE THREAD .....	3/8" F

### DIMENSIONS

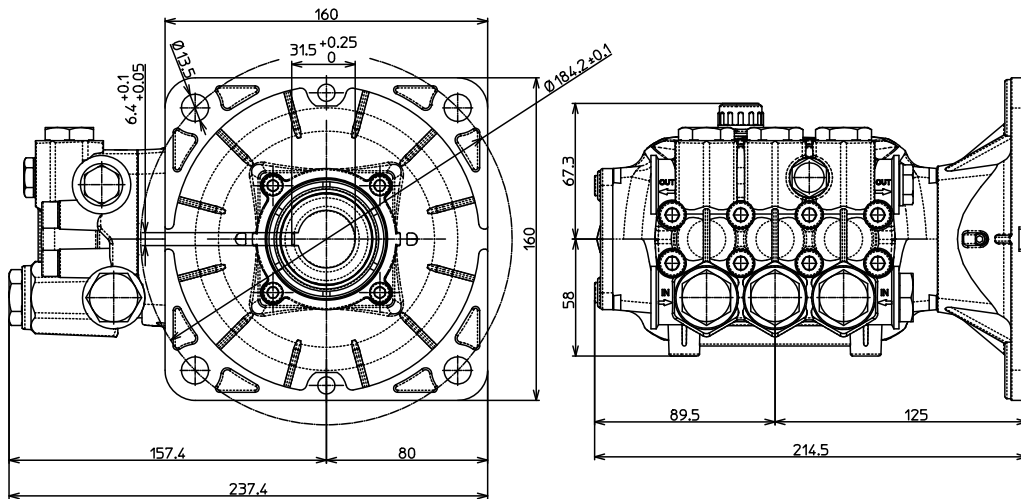

### FEATURING

**Manifold:** High strength forged brass for long term use.

**Bolts:** Eight 6mm.

**Plungers:** NEW Ceramic Plungers, thicker wall to help prevent thermal shock.

**Valves:** Stainless Steel, valve seat o-ring is side mounted.

**Seals:** High quality high pressure seals. NEW low-pressure seal with a built in scraper.

**Piston Guides:** Two piece piston guides.

**Drive End:** NEW connecting rod with 12% more load surface. Large side cover sight glass, oversized bearing. Rear cover oil drain.

**Crankshaft:** Forged, precision ground.