



(Unloader included with pump)

PUMP FEATURES

- Ultimate portability - less than 11 pounds - less than 10" long.
- Unique spring loaded inlet valves and the flow through ceramic plungers provides a smooth, steady flow.
- Optional 3450 or 1725 RPM models for gas or electric drive.
- Regulating Unloader is standard on each pump to assure system pressure control and pump protection.
- Special HT and FPM seals and FPM or EPDM O-Rings for liquid compatibility.

COMMON PUMP SPECIFICATIONS

Inlet Pressure Range (Standard)	Flooded to 75 psi	(Flooded to 5.25 bar)
..... (Hi-Temp)	30 to 75 psi	(2.1 to 5.25 bar)
Bore	0.708"	(18 mm)
Max. Liquid Temperature(Standard)	160°F	(71°C)
..... (Hi-Temp)	190°F	(88°C)
Above 130°F call CAT PUMPS for inlet conditions and elastomer recommendations.		
Crankcase Capacity.....	11.15 oz.	(.33 l)
Inlet Ports (1).....	3/8" NPTF	(3/8" NPTF)
Discharge Ports (2).....	3/8" NPTF	(3/8" NPTF)
By-Pass Ports (1).....	1/4" NPTF	(1/4" NPTF)
Weight (Pump Only).....	10.6 lbs.	(4.8 kg)
Dimensions (Pump Only)	9.13 x 6.65 x 6.50" (232 x 169 x 165mm)	

⚠ CAUTIONS AND WARNINGS

All High Pressure Systems require a primary pressure regulating device (i.e. regulator, unloader) and a secondary pressure relief device (i.e. pop-off valve, relief valve). Failure to install such relief devices could result in personal injury or damage to pump or property. CAT PUMPS does not assume any liability or responsibility for the operation of a customer's high pressure system.

Read all CAUTIONS and WARNINGS before commencing service or operation of any high pressure system. The CAUTIONS and WARNINGS are included in each service manual and with each Accessory Data sheet. CAUTIONS and WARNINGS can also be viewed online at www.catpumps.com/cautions-warnings or can be requested directly from CAT PUMPS.

WARRANTY

View the Limited Warranty on-line at www.catpumps.com/warranty.

Direct-Drive Plunger Pumps

Electric Models **2SF10ES**

2SF20ES, 2SF22ES, 2SF22ELS

2SF29ELS, 2SF30ES, 2SF35ES

Gas Models **2SF30GS, 2SF35GS**

SPECIFICATIONS

	U.S. Measure	Metric Measure	U.S. Measure	Metric Measure
MODEL			2SF10ES	
Flow			1.0 gpm	(3.8 l/m)
Max. Discharge Pressure.....			2000 psi	(140 bar)
Max. RPM.....			3450 rpm	(3450 rpm)
Stroke.....			0.071"	(1.8 mm)
MODEL			2SF20ES	2SF22ES
Flow	2.0 gpm	(7.6 l/m)	2.2 gpm	(8.3 l/m)
Max. Discharge Pressure	2000 psi	(140 bar)	2000 psi	(140 bar)
Max. RPM.....	3450 rpm	(3450 rpm)	3450 rpm	(3450 rpm)
Stroke.....	0.122"	(3.1 mm)	0.132"	(3.35 mm)
MODEL			2SF22ELS	
Flow			2.2 gpm	(8.3 l/m)
Max. Discharge Pressure.....			2000 psi	(140 bar)
Max. RPM.....			1725 rpm	(1725 rpm)
Stroke.....			0.248"	(6.3 mm)
MODEL			2SF29ELS	2SF30ES
Flow	2.85 gpm	(10.8 l/m)	3.0 gpm	(11.4 l/m)
Max. Discharge Pressure	1500 psi	(105 bar)	1500 psi	(105 bar)
Max. RPM.....	1725 rpm	(1725 rpm)	3450 rpm	(3450 rpm)
Stroke.....	0.335"	(8.5 mm)	0.177"	(4.5 mm)
MODEL			2SF30GS	
Flow			3.0 gpm	(11.4 l/m)
Max. Discharge Pressure.....			2000 psi	(140 bar)
Max. RPM.....			3450 rpm	(3450 rpm)
Stroke.....			0.189"	(4.8 mm)
MODEL			2SF35ES	2SF35GS
Flow	3.5 gpm	(13.2 l/m)	3.5 gpm	(13.2 l/m)
Max. Discharge Pressure	1500 psi	(105 bar)	2000 psi	(140 bar)
Max. RPM.....	3450 rpm	(3450 rpm)	3450 rpm	(3450 rpm)
Stroke.....	0.220"	(5.6 mm)	0.220"	(5.6 mm)

Optional Electric-3/4" Shaft - 2SF30GES, 2SF35GES

ES, ELS = **Electric 5/8"** hollow shaft with bolt mount

GES = **Electric 3/4"** hollow shaft with bolt mount

GS = **Gas 3/4"** hollow shaft with bolt and adapter mount

Mounting Flange: SAE J609, Flange A, Extension 3 (3/4"Ø)

Shaft Length: 2.296, Pilot Ø= 1 5/8", B.C. Ø= 3 5/8", Thread= 5/16"-24 UNC Tap

Refer to pump **Service Manual** for repair procedure and additional technical information.

EXPLODED VIEW

October 2012

SF PLUNGER PUMP MODELS

2SF10, 2SF20, 2SF22, 2SF29, 2SF30, 2SF35

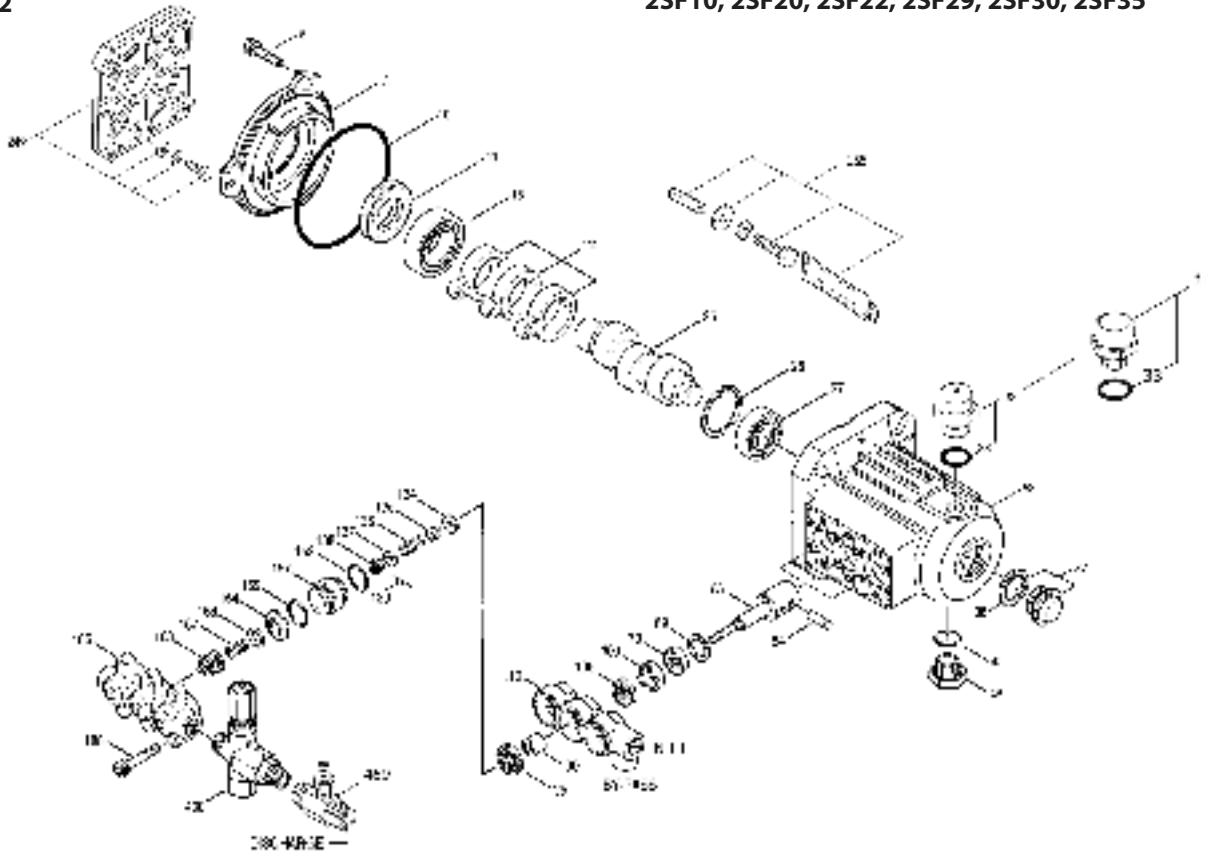

PARTS LIST

ITEM	P/N	MATL	DESCRIPTION	MODEL USED	QTY	ITEM	P/N	MATL	DESCRIPTION	MODEL USED	QTY
5	549360	STCP R	Screw, HH (M6x14)	All Models	3	134	45854	S	Valve, Inlet	All Models	3
8	547153	AL	Cover, Bearing, Inner [3/03]	All Models	1	135	549520	S	Spacer, Inlet	All Models	3
10	14041	NBR	O-Ring, Bearing Cover - 70D [3/03]	All Models	1	136	44872	S	Spring, Inlet Valve	All Models	3
11	55337	NBR	Seal, Oil [3/03]	All Models	1	137	88575	S	Washer, Conical (M6)	All Models	3
15	14488	STL	Bearing, Ball, Inner	All Models	1	138	27000	S	Nut, Slotted (M6)	All Models	3
20	547046	TNM	Rod, Connecting	All Models	3	139	14158	S	Cotterpin (M1.6x10)	All Models	3
25	831987	CM	Crankshaft, 3450 RPM, 5/8", 1.8mm	10ES	1	152	26089	NBR	O-Ring, Adapter, Inner - 80D	All Models	3
	46109	CM	Crankshaft, 3450 RPM, 5/8", 3.1mm	20ES	1		11377	FPM	O-Ring, Adapter, Inner - 80D	All Models	3
	46074	CM	Crankshaft, 3450 RPM, 3/4", 3.35mm	22GS	1		46647	EPDM	O-Ring, Adapter, Inner - 80D	All Models	3
	44929	CM	Crankshaft, 3450 RPM, 5/8", 3.35mm	22ES	1	157	44878	BB	Discharge Valve Adapter	All Models except 29ELS	3
	546334	CM	Crankshaft, 3450 RPM, 3/4", 4.8mm	30GS	1		45430	BB	Discharge Valve Adapter	29ELS	3
	44931	CM	Crankshaft, 3450 RPM, 5/8", 4.5mm	30ES	1	159	26089	NBR	O-Ring, Adapter, Outer - 80D	All Models	3
	45096	CM	Crankshaft, 3450 RPM, 5/8", 5.6mm	35ES	1		11377	FPM	O-Ring, Adapter, Outer - 80D	All Models	3
	46017	CM	Crankshaft, 3450 RPM, 3/4", 5.6mm	35GS	1		46647	EPDM	O-Ring, Adapter, Outer - 80D	All Models	3
	45160	CM	Crankshaft, 1725 RPM, 5/8", 6.3mm	22ELS	1	164	44881	S	Seat	All Models	3
	45914	CM	Crankshaft, 1725 RPM, 5/8", 8.5mm	29ELS	1	166	43723	S	Valve	All Models	3
26	12385	STL	Ring, Retaining	All Models	1	167	541062	S	Spring	All Models	3
27	15710	STL	Bearing, Ball, Outer	All Models	1	168	44565	PVDF	Retainer, Spring	All Models	3
31	549726	—	Cap, Vented w/O-Ring (Rain Cap)	All Models	1	185	44879	BB	Manifold, Discharge	All Models	1
32	547961	RTP	Cap, Oil Filler w/O-Ring	All Models	1	188	126762	STCP R	Screw, HSH (M8x75)	All Models	6
33	14179	NBR	O-Ring, Oil Filler Cap - 70D	All Models	1	249	30520	—	Assy, Adapter Mount, Gas	30GS, 35GS	1
37	92241	—	Gauge, Bubble Oil w/Gasket - 80D	All Models	1	255	30517	STZP R	Assy, Bolt Mount	All Models	1
38	44428	NBR	Gasket, Flat Flex., Oil Gauge - 80D	All Models	1	283	990394	—	Kit, Oil Drain (Not Shown)	All Models	1
48	44842	NY	Plug, Drain (1/2" NPT)	All Models	1	285	80228	STL	Screw (M8-1.25x80) (Not Shown)	All Models	2
49	14179	NBR	O-Ring, Drain Plug - 70D	All Models	1	300	34053	NBR	Kit, Seal (Incls: 106,125,139,152,159)	All Models	7
53	547285	AL	Crankcase [3/03] (See Tech Bulletin 092)	All Models	1		33953	HT	Kit, Seal-Hi-Temp (Incls: 106,125,134,139,152,159)	All Models	7
64	16948	CM	Pin, Crosshead	All Models	3		33453	FPM	Kit, Seal (Incls: 106,125,139,152,159)	All Models	7
65	44865	SCP	Rod, Plunger	All Models except 29ELS	3		30536	EPDM	Kit, Seal (Incls: 106,125,139,152,159)	All Models	7
	45427	SZZ	Rod, Plunger	29ELS	3	310	34052	NBR	Kit, Valve (Incls: 152,159,164,166,167,168)	All Models	7
69	126259	STCP R	Washer (M24)	All Models	3	311	34668	NBR	Kit, Inlet Valve (Incls: 134-137,139,152,159)	All Models	7
70	25461	NBR	Seal, Oil	All Models	3	352	44050	STZP	Tool, Oil Gauge Removal	All Models	1
90	45847	CC	Plunger (M18x14)	All Models except 29ELS	3	400	75005	BB	Unloader, Regulating	All Models	7
	45429	CC	Plunger (M18x16)	29ELS	3	469	7192	BB	Injector, Chemical (1.8 mm Adjustable)	All Models	7
100	44869	PVDF	Retainer, Seal	All Models	3		7193	BB	Injector, Chemical (2.1 mm Adjustable)	All Models	7
106	44876	NBR	Seal, LPS w/S-Spg	All Models	3		7194	BB	Injector, Chemical (2.3 mm Adjustable)	All Models	7
	545192	FPM	Seal, LPS w/SS-Spg	All Models	3		6575	—	Plunger Pump Service DVD	All Models	7
	546507	EPDM	Seal, LPS w/SS-Spg	All Models	3		6107	—	Oil, Bottle (2.1 oz) ISO 68 Hydraulic	All Models	7
110	44874	BB	Manifold, Inlet	All Models	1				(Fill to specified crankcase capacity prior to start-up)		
125	43245	SNG	Seal, HPS w/S	All Models	3						
	46652	HT*	Seal, HPS "Hi-Temp" 2-Pc w/S-Support	All Models	3						

Bold print part numbers are unique to a particular pump model. Italics are optional items. [] Date of latest production change. R Components comply with RoHS Directive.

◆ Silicone Oil /Grease required. View Tech Bulletins 002, 024, 036, 043, 055, 060, 064, 065, 070, 073, 074, 083, 091 and 092 for additional information.

NOTE: Discard Key which may come standard with most motors and engines and use only the key included in this kit.

MATERIAL CODES (Not Part of Part Number): AL=Aluminum BB=Brass CC=Ceramic CM=Chrome-Moly FPM=Fluorocarbon

HT=Hi-Temp (EPDM Alternative) LDPE=Low Density Polyethylene NBR=Medium Nitrile (Buna-N) NY=Nylon PVDF=Polyvinylidene Fluoride RTP=Reinforced Composite
S=304SS SCP=304SS/Chrome Plated SNG=Special Blend (Buna) STL=Steel STCP=Steel/Chrome Plated STZP=Steel/Zinc Plated SZZ=304SS/Zamak TNM=Special High Strength

Center raised pilot guide on the **Adapter Plate** assures proper alignment of pump and engine. Before mounting pump onto engine inspect engine for **recessed seal and bearing guide** to permit adapter to completely seat into recess and four bosses to be flush with engine face.

EXPLODED VIEW

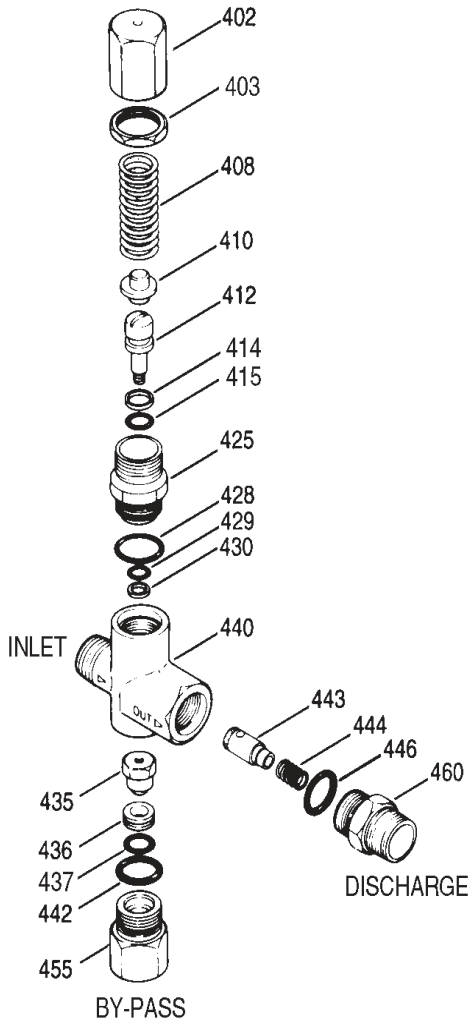

PARTS LIST

ITEM	P/N	MATL	DESCRIPTION	QTY.
402	540081	BB	Cap, Hex Adjusting	1
403	31047	BB	Nut, Lock (M18 x 1)	1
408	32094	STZP R	Spring, Pressure	1
410	107672	BB	Retainer, Spring	1
412	45694	S	Stem, Piston (M5)	1
414	20184	PTFE	Back-up-Ring, Piston Stem	1
415	14190	NBR	O-Ring, Piston Stem - 70D	1
	14161	FPM	O-Ring, Piston Stem - 70D	1
	◆ 48239	EPDM	O-Ring, Piston Stem	1
425	107673	BB	Retainer, Piston	1
428	13969	NBR	O-Ring, Piston Retainer - 70D	1
	14320	FPM	O-Ring, Piston Retainer - 70D	1
	◆ 547313	EPDM	O-Ring, Piston Retainer - 70D	1
429	14759	NBR	O-Ring, Body	1
	14160	FPM	O-Ring, Body - 80D	1
	◆ 46204	EPDM	O-Ring, Body - 70D	1
430	107675	PTFE	Back-up-Ring, Body	1
435	45696	BB	Valve and Ball Assembly (M5)	1
436	107680	S	Seat	1
437	13963	NBR	O-Ring, Seat - 70D	1
	14303	FPM	O-Ring, Seat - 70D	1
	◆ 547319	EPDM	O-Ring, Body - 70D	1
440	—	BB	Body	1
442	13969	NBR	O-Ring, By-Pass Fitting - 70D	1
	14320	FPM	O-Ring, By-Pass Fitting - 70D	1
	◆ 547313	EPDM	O-Ring, By-Pass Fitting - 70D	1
443	541060	BB	Valve, Check w/O-Ring	1
444	45924	S	Spring	1
446	13969	NBR	O-Ring, Discharge Fitting - 70D	1
	14320	FPM	O-Ring, Discharge Fitting - 70D	1
	◆ 547313	EPDM	O-Ring, Discharge Fitting - 70D	1
455	45695	BB	Fitting, By-Pass (3/8" NPTF)	1
460	107681	BB	Fitting, Discharge (3/8" NPTM)	1
465	7090	BB	By-Pass Hose (15" x 3/8")	1
466	7090.40	BB	By-Pass Hose w/Thermo Valve	1
	7090.35	RTP	By-Pass Hose w/Thermo Valve	1
468	32097	NBR	Kit, O-Ring (Incls: 414,415, 428, 429, 430, 437, 442, 446)	1
	31627	FPM	Kit, O-Ring (Incls: 414,415, 428, 429, 430, 437, 442, 446)	1
	◆ 31959	EPDM	Kit, O-Ring (Incls: 414,415, 428, 429, 430, 437, 442, 446)	1

Italics are optional items. R Components comply with RoHS Directive.

◆ Silicone Oil/Grease Required. MATERIAL CODES (Not Part of Part Number): BB=Brass
FPM=Fluorocarbon NBR=Medium Nitrile (Buna-N) PTFE=Pure Polytetrafluoroethylene S=304SS
STZP=Steel/Zinc Plated

7500S UNLOADER SPECIFICATIONS

	U.S. Measure	Metric Measure
Flow Range.....	0.5-6.0 gpm	(1.89-23 l/m)
Pressure Range.....	100-2000 psi	(7-140 bar)
Inlet Port - Rear.....	3/8" NPTM	(3/8" NPTM)
Discharge Port - Front.....	M18 x 1.0	(M18 x 1.0)
By-pass Port - Bottom.....	3/8" NPTF	(3/8" NPTF)
Weight.....	14.4 oz.	(0.41 kg)
Dimensions.....	3.0 x 1.0 x 4.25"	(76 x 25 x 108 mm)

UNLOADER TYPE

Each pump comes with a pressure sensitive regulating unloader. This unloader will set system pressure. While in by-pass the line pressure will drop to a low pressure mode and then quickly build up to set system pressure when the system is back to full use.

INSTALLATION AND START-UP

Install a pressure gauge close to the manifold head of the pump to assist in setting system pressure and to periodically monitor system pressure. By-pass line can be directed to the ground, or to a reservoir or be redirected to the 1/4" NPTF port on bottom side of inlet manifold. If routing to pump inlet use a 3/8" flexible hose and thermo valve.

NOTE: If not using a thermo valve **DO NOT EXCEED 6 MINUTES** in by-pass.

NOTE: For Hi-Temp seal pumps **DO NOT USE THERMO VALVE**, use optional dual pressure switches and mechanical relays.

Pump should be purged of air before commencing with operation. Liquid must flow through the pump without discharge restriction to assure full system pressure is reached.

Setting and adjusting the unloader pressure must be done with the system turned on. Start the system with the unloader backed off to the lowest pressure setting (counterclockwise direction). Squeeze the trigger and read the pressure on the gauge at the pump. Do not read pressure at the gun or nozzle. If more pressure is desired, release the trigger, turn adjusting cap one quarter turn in a clockwise direction. Squeeze the trigger and read the pressure. Repeat this process until the desired system pressure is reached. Thread locking nut up to adjusting cap.

NOTE: Pressure is not set at the factory.

SERVICE

The unloader should be serviced on the same schedule as the seals in the pump. Refer to SF Plunger Pump Service Manual for start-up, servicing of seals and valves, torque requirements and diagnosis and maintenance chart.

MOTOR SPECIFICATIONS

Model 8050

Horsepower	1.5
Shaft Diameter	5/8"
Max. Volts	115/230
FULL LOAD AMPS	12.1
RPM	3450
Weight	32.1 lbs.
Phase	Single
Frame Size	56-C TEFC
Service Factor	1.15

Model 8055

Horsepower	3.0
Shaft Diameter	● 3/4"
Max. Volts	230
FULL LOAD AMPS	15.2/13.6
RPM	3450
Weight	46.3 lbs.
Phase	Single
Frame Size	56-C TEFC
Service Factor	1.15

● Use 3/4" shaft size motor with GES Models.

★ Model 8060

Horsepower	1.5
Shaft Diameter	5/8"
Max. Volts	115/230
FULL LOAD AMPS	14.0/7.0
RPM	1725
Weight	40 lbs.
Phase	Single
Frame Size	56-C TEFC
Service Factor	1.2

★ Use with ELS models or to reduce flow by 50% on standard models.

Model 8125

Horsepower	2.5
Shaft Diameter	5/8"
Max. Volts	110/220, 115/230
FULL LOAD AMPS	23.6/11.8, 21/11.5
RPM	1450, 1750
Weight	52.9 lbs.
Phase	Single
Hertz	50/60
Frame Size	56-C TEFC
Service Factor	1.0, 1.2

Model 8052

Horsepower	2.0
Shaft Diameter	5/8"
Max. Volts	115/230
FULL LOAD AMPS	17.0/9.2-8.5
RPM	3450
Weight	32.5 lbs.
Phase	Single
Frame Size	56-C TEFC
Service Factor	1.15

Model 8057

Horsepower	5.0
Shaft Diameter	● 3/4"
Max. Volts	230
FULL LOAD AMPS	22.0
RPM	3450
Weight	40 lbs.
Phase	Single
Frame Size	56-C OPEN DRIP
Service Factor	1.15

● Use 3/4" shaft size motor with GES Models.

★ Model 8062

Horsepower	2.0
Shaft Diameter	5/8"
Max. Volts	115/230
FULL LOAD AMPS	17.0/8.5
RPM	1725
Weight	43.7 lbs.
Phase	Single
Frame Size	56-C TEFC
Service Factor	1.15

★ Use with ELS models or to reduce flow by 50% on standard models.

Common Motor Specifications

Max. Ambient Temp	104°F
Capacitor Start	Yes
Thermal Overload-Manual Reset....	Yes
Hertz	60

Note: Motor Start-Up AMPS may vary, then settle within FULL LOAD AMPS rating after initial run in time.

★★ Before mounting pump on motor, apply P.N. 6106 Antiseize Lubricant to pump shaft.

★★ Refer to Tech Bulletin 055 for instructions on removing pump from gas engine or electric motor.

For warranty consideration contact CAT PUMPS for the local **Authorized Service Center**. If you are uncertain as to the cause of failure (Pump or Motor), secure **Returned Goods Authorization number** and return complete assembly **PREPAID** to CAT PUMPS for evaluation.

ELECTRIC HORSEPOWER REQUIREMENTS

FLOW		PRESSURE					PUMP RPM
		psi 700	psi 1000	psi 1200	psi 1500	psi 2000	
U.S. gpm	Metric l/m	bar 50	bar 70	bar 85	bar 105	bar 140	
1.0	3.8	.48	.68	.82	1.0	1.4	3450
2.2	8.3	1.1	1.5	1.8	2.3	3.0	1725/3450
2.85	10.8	1.36	2.0	2.3	2.9	N/A	1725
3.0	11.4	1.4	2.1	2.5	3.1	4.1	3450
3.5	13.2	1.67	2.39	2.87	3.59	N/A	3450

DETERMINING THE REQUIRED H.P.

$$\frac{\text{gpm} \times \text{psi}}{1460} = \text{Electric Brake H.P. Required}$$

2SF DIMENSIONAL DRAWING

MODEL	8050	8052	8055	8057	8060	8062	8125
Dimension A	18.2	18.2	20.0	18.7	18.7	19.2	19.1
Dimension B	11.3	11.3	13.1	11.8	11.8	12.3	12.2
Dimension C	8.4	8.4	8.3	9.0	8.1	8.1	9.6
Dimension D	9.5	9.5	9.5	9.5	9.5	9.5	9.7

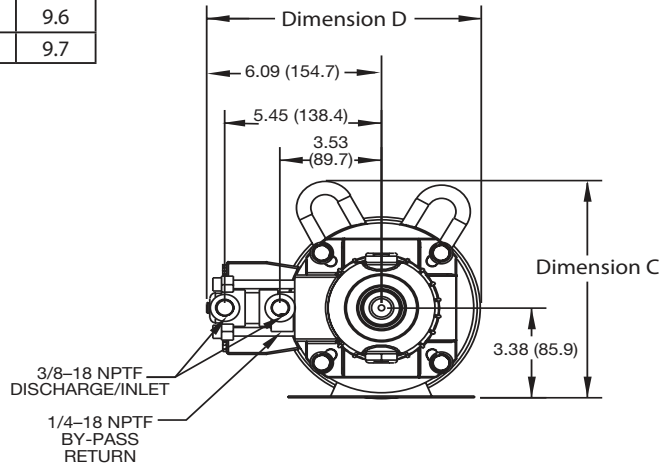
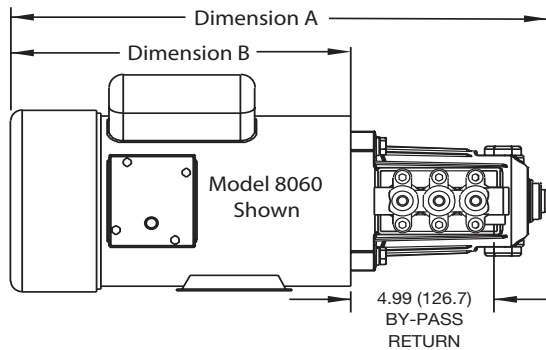

CAT PUMPS
 1681 - 94TH LANE N.E. MINNEAPOLIS, MN 55449-4324
 PHONE (763) 780-5440 — FAX (763) 780-2958
 e-mail: techsupport@catpumps.com
 www.catpumps.com