

TC Series "60"

Triples Plunger Pump, 3/4" Hollow Shaft Flanged for Direct Couple To Gas Engine

FEATURES

- Compact design
- 3/4" hollow shaft, flanged for direct couple to gasoline engines (SAE J609A)
- Oversized bearings for long life
- New generation seal system for longer life
- Forged brass manifold with an exclusive lifetime warranty*



SPECIFICATIONS

Pump Model	TC1506G	TC1507G	TC1508G	TC1509G
Maximum Volume	2.60 GPM	3.00 GPM	3.30 GPM	4.00 GPM
Maximum Discharge Pressure	2700 PSI		2500 PSI	
Horsepower	7.21 GHP	8.32 GHP	8.48 GHP	10.27 GHP
Maximum Pump Speed	3400 RPM			
Maximum Inlet Pressure	125 PSI			
Minimum Inlet Pressure	Flooded			
Plunger Bore (in / mm)	.591 in / 15 mm			
Plunger Stroke (in / mm)	.256 in / 6.5 mm	.283 in / 7.2 mm	.315 in / 8.0 mm	.370 in / 9.4 mm
Oil Capacity	11.8 oz			
Maximum Fluid Temperature	165°F			
Inlet Port Thread	1/2" - 14 BSP-F			
Discharge Port Thread	3/8" - 19 BSP-F			
Shaft Diameter	.748 in / 19 mm			
Weight	14.6 lbs			
Dimensions	7.6 x 7.6 x 5.0 in			

DIMENSIONAL DRAWING

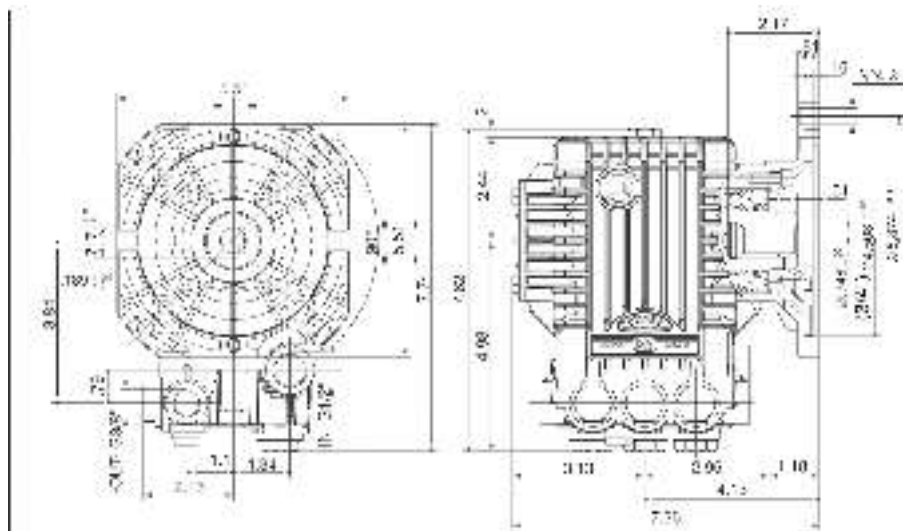

TRIPLEX

TRIPLEX



General Pump
is a member of
the Interpump Group



TC Series "60"

GENERAL PUMP *A member of the Interpump Group*

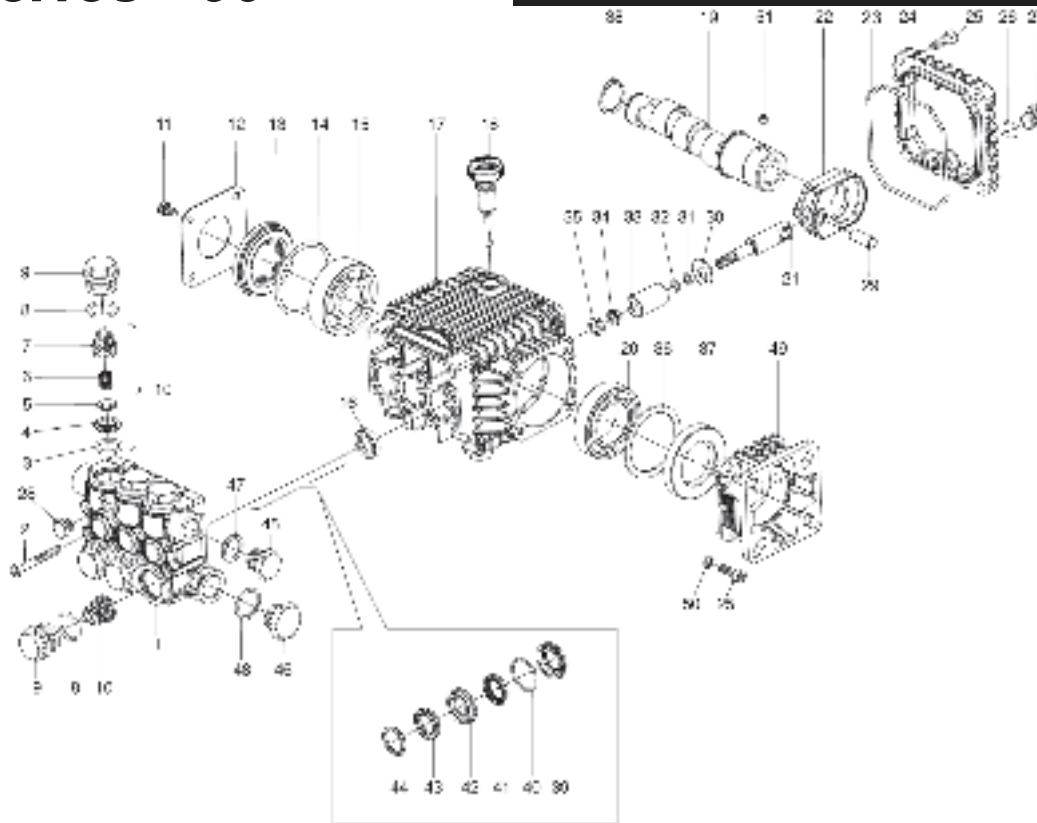

PARTS LIST

ITEM	PART NO.	DESCRIPTION	KIT NO.	QTY.	ITEM	PART NO.	DESCRIPTION	KIT NO.	QTY.	ITEM	PART NO.	DESCRIPTION	KIT NO.	QTY.
1.	60120041	Manifold, 15 mm		1	19.	60027565	Crankshaft, TC1508G		1	38.	90063500	Circlip		1
2.	99195000	Screw, M6 x 45		8		60027865	Crankshaft, TC1509G		1	39.	60080070	Seal, LP,15mm	200,226	3
3.	90384100	O-ring	123	6	20.	91846400	Bearing		1	40.	90360400	O-ring,	200,226	3
4.	36200366	Valve Seat	123	6	21.	60050066	Plunger Guide		3	41.	90260800	Seal, LP, 15 mm	196,226	3
5.	36200176	Valve	123	6	22.	60030022	Connecting Rod		3	42.	60216070	Intermediate Ring, 15	198,226	3
6.	94737600	Spring	123	6	23.	90391800	O-ring, Cover		1	43.	90262000	Seal, HP, 15mm	196,226	3
7.	36202551	Valve Cage	123	6	24.	60160022	Rear Crankcase Cover		1	44.	51100051	Head Ring, 15mm	196,226	3
8.	90384700	O-ring		6	25.	99186700	Screw, M6 x 18		8	45.	98210000	Plug, 3/8" G		1
9.	98221400	Valve Cap		6	26.	90358500	O-ring		1	46.	98217600	Plug, 1/2" G		1
10.	36711501	Valve Assembly	123	6	27.	98204100	Plug, 1/4" G		1	47.	96738000	Gasket, Alum., 3/8"		1
11.	99180700	Screw, M6 x 10		4	28.	98196600	Plug, 1/8" G		1	48.	96751400	Gasket, Alum., 1/2"		1
12.	50150074	Bearing Cover		1	29.	97733300	Wrist Pin		3	49.	10065222	Flange		1
13.	44211801	Oil Level Indicator		1	30.	96707000	Washer		3	50.	96693800	Washer		4
14.	90409700	O-ring		1	31.	90502200	Anti-ext. Ring		3	51.	99179000	Screw, M6		1
15.	91832800	Ball Bearing		1	32.	90357300	O-ring		3					
16.	90156500	Oil Seal	83	3	33.	60040009	Ceramic Plunger, 15mm		3					
17.	60010022	Crankcase		1	34.	44211570	Bushing		3					
18.	98210300	Oil Dip Stick		1	35.	92221600	Nut, M8		3					
19.	60027165	Crankshaft, TC1506G		1	36.	60210189	Spacer		1					
	60027365	Crankshaft, TC1507G		1	37.	90167500	Oil Seal		1					

REPAIR KITS

KIT NO.	K83	K123	K196 (15mm)	K198 (15mm)	K200 (15mm)	K226 (15mm)
ITEM NO's INCLUDED IN KIT	16	3, 4, 5, 6, 7 (10)	41, 43, 44	42	39, 40	39, 40, 41, 42, 43, 44
NUMBER OF ASSEMBLIES IN KIT	3	6	3	3	3	1
NUMBER OF CYLINDERS KIT WILL SERVICE	3	3	3	3	3	1

TORQUE SPECS*

Pos.	Ft/lb	Nm
2	8.8	12
9	59.0	80
11	7.4	10
25	7.4	10
27	14.7	20
28	9.6	13
35	11.1	15
44	29.5	40
46	29.5	40

* Decrease torque by 20% if threads are lubricated

